

















A close-up, high-contrast photograph of a metal reamer tool. The tool's surface is highly textured with fine, parallel ridges and grooves, characteristic of a reamer's cutting edge. The lighting is dramatic, highlighting the metallic sheen and the intricate details of the tool's geometry against a dark background.

Escariado >
Alésage
Reaming

Escariadores de mano / Alésos à main / Hand reamers									
4101	HSS	DIN 206		Form. B 8° Tol. H7 ISO 236	P K N	283			
4102	HSS	DIN 9		Form. B 8° 2% ISO 3465	P K N	284			
4119	HSS			Form. B 8° C. 1:16 (NPT-BSPT)	P K N	284			
Escariadores de máquina / Alésos machine / Machine reamers									
4118	HM-MD	DIN 212		Form. B-D 8° Tol. H7 ISO 521	P M K N S H	285			
4104	HSSCO	DIN 212		Form. B 8° Tol. H7 ISO 521	P M K N S	286			
4105	HSSCO	DIN 212		Form. E 45° Tol. H7 ISO 521	P N	287			
4103	HSSCO	DIN 2179		Form. E 45° 2% ISO 3466	P K N	288			
4106	HSSCO	DIN 208		Form. B 8° Tol. H7 ISO 521	P M K N S	288			
4107	HSSCO	DIN 208		Form. C 45° Tol. H7 ISO 521	P N	289			
4108	HSS	DIN 311		25° ISO 2238	P K N	289			
Escariadores de máquina entrada cónica / Alésos machine pour goupilles coniques / Machine reamers for taper holes									
4115	HSSCO	DIN 212		45° 5%	P K N	290			
4116	HSSCO	DIN 212		45° 8%	P K N	290			
4117	HSSCO	DIN 212		45° 10%	P K N	291			
Escariadores huecos / Alésos creux finisseurs à machine / Hole machine reamers									
4109	HSS	DIN 219		Form. B 8° Tol. H7 ISO 2402	P M K N S	291			
4114	HSS					292			
Escariadores extensibles / Alésos extensibles / Extendable reamers									
4110	HSS			Form. A REFORZ. RENFORC. RENFORC.	P K N	292			
4111	HSS			Form. A	P K N	293			

FORMULARIO ESCARIADORES / AVELLANADORES ESPECIALES
FICHE TECHNIQUE ALESOIRS ET FRAISES A TROU SPECIAUX
TECHNICAL ENQUIRY FOR SPECIAL REAMERS AND COUNTERSINK CUTTERS

Fecha / Date:

Empresa / Entreprise / Company: Contacto / Contact:

Dirección / Adresse / Address: Población / Ville / Town:

Tel / Fax: E-mail:

TRABAJO A REALIZAR / TRAVAIL DEMANDE / REQUESTED WORK

Material / Matière / Material Norma / Norme / Norm:

Dureza / Durété / Hardness HB HRC Resistencia / Résistance / Resistance N/mm²

Tipo viruta: Corta Larga Polvo
 Type copeau Courte Longue Poussière
 Shaving Short Long Powder

Máquina / Machine Refrigerante / Réfrigérant / Coolant

Posición / Position Horizontal Vertical V. Corte V. avance
 V. Coupe Avance
 Cutting Speed Feed

HERRAMIENTA / OUTIL / TOOL

Descripción / Description Tolerancia / Tolérance / Tolerance

Cantidad / Quantité / Quantity Número ranuras / Rainures / Grooves

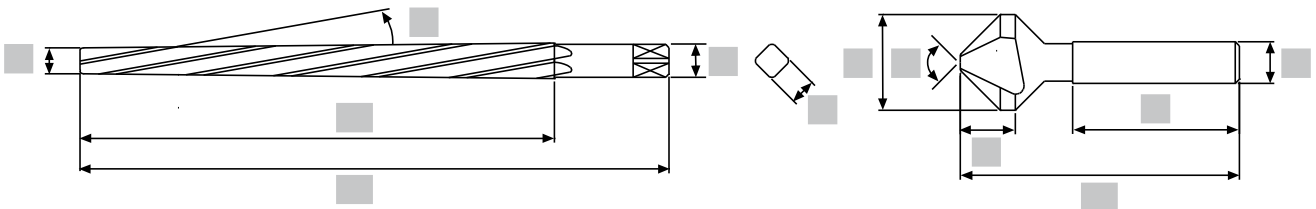

Mango: Cilíndrico Weldon Cónico Rebajado
 Queue: Cylindrique Weldon Conique Réduite
 Shank: Straight Weldon Taper Reduced

Material / Matière / Material: HSS HSSE HM HSS-HM

Superficie / Surface: Brillante Negra Recubrimiento
 Brillant Noire Revêtement
 Brilliant Black Coating

COMENTARIOS / COMMENTAIRES/ COMMENTS:

.....



TABLA DE APLICACIONES GUIDE D'APPLICATION / APPLICATION GUIDE



$$r.p.m. = \frac{V_c \times 1.000}{\pi \times \phi}$$

Ref./ Réf. / Ref.	4118	4104
Form.	B	B
Hel./Hél./Spiral	8°	8°
Mat.	HM	HSSCO
Rec./Rev./Coating		
DIN	212	212
Tol.	H7	H7
Gama/Gamme/Range	2-12	1-20
Pag.	285	286

Mat.	Avance/Feed (mm/rpm)																		Vc (m/min)		
	Ø2	Ø5	Ø10	Ø15	Ø20	Ø25	Ø30	Ø35	Ø40	Ø2	Ø5	Ø10	Ø15	Ø20	Ø25	Ø30	Ø35	Ø40	●	○	
P.1	<600	0,05	0,1	0,2	0,26	0,33	0,4	0,45	0,5	0,55	0,08	0,16	0,3	0,4	0,5	0,6	0,7	0,75	0,8	●	●
P.2	<800	0,05	0,1	0,2	0,26	0,33	0,4	0,45	0,5	0,55	0,08	0,16	0,3	0,4	0,5	0,6	0,7	0,75	0,8	●	●
P.3	<1000	0,04	0,08	0,16	0,2	0,25	0,32	0,36	0,4	0,43	0,63	0,12	0,25	0,3	0,4	0,5	0,53	0,56	0,6	●	●
P.4	<1200	0,03	0,06	0,12	0,16	0,2	0,25	0,28	0,32	0,35	0,05	0,1	0,2	0,26	0,33	0,4	0,45	0,5	0,55	●	○
P.5	<1400										0,04	0,08	0,16	0,2	0,25	0,32	0,36	0,4	0,43	●	○
M.1	<950	0,03	0,06	0,12	0,16	0,2	0,25	0,28	0,32	0,35	0,03	0,06	0,12	0,16	0,2	0,25	0,28	0,32	0,35	●	●
M.2		0,03	0,06	0,12	0,16	0,2	0,25	0,28	0,32	0,35	0,03	0,06	0,12	0,16	0,2	0,25	0,28	0,32	0,35	●	●
M.3	<1200	0,02	0,05	0,1	0,12	0,16	0,2	0,23	0,25	0,27	0,02	0,05	0,1	0,12	0,16	0,2	0,23	0,25	0,27	●	○
M.4		0,02	0,05	0,1	0,12	0,16	0,2	0,23	0,25	0,27	0,02	0,05	0,1	0,12	0,16	0,2	0,23	0,25	0,27	●	○
K.1	<500	0,05	0,1	0,2	0,26	0,33	0,4	0,45	0,5	0,55	0,08	0,16	0,3	0,4	0,5	0,6	0,7	0,75	0,8	●	●
K.2																					
K.3	<800	0,04	0,08	0,16	0,2	0,25	0,32	0,36	0,4	0,43	0,04	0,08	0,16	0,2	0,25	0,32	0,36	0,4	0,43	●	○
K.4.1		0,04	0,08	0,16	0,2	0,25	0,32	0,36	0,4	0,43	0,63	0,12	0,25	0,3	0,4	0,5	0,53	0,56	0,6	●	●
K.4.2	<1400										0,04	0,08	0,16	0,2	0,25	0,32	0,36	0,4	0,43	●	○
N.1.1	Al	0,08	0,16	0,3	0,4	0,5	0,6	0,7	0,75	0,8	0,1	0,2	0,4	0,5	0,65	0,8	0,9	0,95	1	●	●
N.1.2		0,63	0,12	0,25	0,3	0,4	0,5	0,53	0,56	0,6	0,1	0,2	0,4	0,5	0,65	0,8	0,9	0,95	1	●	●
N.1.3		0,63	0,12	0,25	0,3	0,4	0,5	0,53	0,56	0,6	0,1	0,2	0,4	0,5	0,65	0,8	0,9	0,95	1	●	●
N.2.1	Cu	0,63	0,12	0,25	0,3	0,4	0,5	0,53	0,56	0,6	0,08	0,16	0,3	0,4	0,5	0,6	0,7	0,75	0,8	●	●
N.2.2		0,63	0,12	0,25	0,3	0,4	0,5	0,53	0,56	0,6	0,1	0,2	0,4	0,5	0,65	0,8	0,9	0,95	1	●	●
N.2.3		0,63	0,12	0,25	0,3	0,4	0,5	0,53	0,56	0,6	0,08	0,16	0,3	0,4	0,5	0,6	0,7	0,75	0,8	●	●
N.2.4																					
N.3.1	Mg/Zn	0,63	0,12	0,25	0,3	0,4	0,5	0,53	0,56	0,6	0,1	0,2	0,4	0,5	0,65	0,8	0,9	0,95	1	●	○
N.4.1	Plastic	0,1	0,2	0,4	0,5	0,65	0,8	0,9	0,95	1	0,1	0,2	0,4	0,5	0,65	0,8	0,9	0,95	1	●	●
N.4.2		0,08	0,16	0,3	0,4	0,5	0,6	0,7	0,75	0,8	0,1	0,2	0,4	0,5	0,65	0,8	0,9	0,95	1	●	●
N.4.3																					
S.1.1	Ni	0,04	0,08	0,16	0,2	0,25	0,32	0,36	0,4	0,43	0,05	0,1	0,2	0,26	0,33	0,4	0,45	0,5	0,55	●	○
S.1.2		0,03	0,06	0,12	0,16	0,2	0,25	0,28	0,32	0,35	0,04	0,08	0,16	0,2	0,25	0,32	0,36	0,4	0,43	●	○
S.2.1	Ti	0,04	0,08	0,16	0,2	0,25	0,32	0,36	0,4	0,43	0,05	0,1	0,2	0,26	0,33	0,4	0,45	0,5	0,55	●	●
S.2.2		0,04	0,08	0,16	0,2	0,25	0,32	0,36	0,4	0,43	0,05	0,1	0,2	0,26	0,33	0,4	0,45	0,5	0,55	●	○
S.2.3		0,03	0,06	0,12	0,16	0,2	0,25	0,28	0,32	0,35	0,04	0,08	0,16	0,2	0,25	0,32	0,36	0,4	0,43	●	○
H.1	50 HRC										0,03	0,06	0,12	0,16	0,2	0,25	0,28	0,32	0,35	●	○
H.2	55 HRC										0,03	0,06	0,12	0,16	0,2	0,25	0,28	0,32	0,35	●	○
H.3	60 HRC										0,02	0,05	0,1	0,12	0,16	0,2	0,23	0,25	0,27	○	○

● Optima / Optimun ○ Alternativo / Alternative



4105	4103	4106	4107	4108	4115	4116	4117	4109
E	E	B	C					B
45°	45°	8°	45°	25°	45°	46°	47°	8°
HSSCO	HSSCO	HSSCO	HSSCO	HSSCO	HSSCO	HSSCO	HSSCO	HSS
212	2179	208	208	311	212	212	212	219
H7		H7	H7					H7
3-16	3-10	4-40	5-29	10-37	3-7	3-6	2-6	32-80
287	288	288	289	289	290	290	291	291
• 12-16	• 8-12	• 10-14	• 12-16	• 8-12	• 8-12	• 8-12	• 8-12	• 10-14
• 10-14	• 6-12	• 8-12	• 10-14	• 6-12	• 6-12	• 6-12	• 6-12	• 8-12
	○ 4-6	• 6-8		○ 4-6	○ 4-6	○ 4-6	○ 4-6	○ 6-8
		○ 4-6						
	○ 4-6	• 6-8		○ 4-6	○ 4-6	○ 4-6	○ 4-6	• 6-8
	○ 4-6	• 6-8		○ 4-6	○ 4-6	○ 4-6	○ 4-6	• 6-8
		○ 4-6						
		○ 4-6						
	• 10-14	• 12-16		• 10-14	• 10-14	• 10-14	• 10-14	• 10-14
		○ 6-8						○ 6-8
	• 6-8	• 10-12		• 6-8	• 6-8	• 6-8	• 6-8	• 10-12
• 20-25	• 16-22	• 20-25	• 20-25	• 16-22	• 16-22	• 16-22	• 16-22	• 20-25
• 16-22	• 14-20	• 16-22	• 16-22	• 14-20	• 14-20	• 14-20	• 14-20	• 16-22
• 14-20	• 8-12	• 14-20	• 14-20	• 8-12	• 8-12	• 8-12	• 8-12	• 14-20
	• 10-16	• 12-20		• 10-16	• 10-16	• 10-16	• 10-16	• 12-20
	• 16-22	• 20-25		• 16-22	• 16-22	• 16-22	• 16-22	• 20-25
• 14-20	• 12-18	• 16-22	• 14-20	• 12-18	• 12-18	• 12-18	• 12-18	• 16-22
		○ 12-16						○ 12-16
• 12-16	• 16-22	• 10-14	• 12-16	• 16-22	• 16-22	• 16-22	• 16-22	• 10-14
• 10-14	• 14-20	• 8-10	• 10-14	• 14-20	• 14-20	• 14-20	• 14-20	• 8-10
		○ 1-3						○ 1-3
		○ 1-3						
	○ 4-6	• 6-8		○ 4-6	○ 4-6	○ 4-6	○ 4-6	• 6-8
		○ 2-6						○ 2-6
		○ 2-6						

● Optima / Optimun ○ Alternativo / Alternative



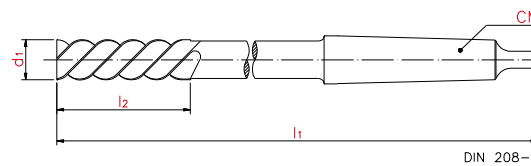
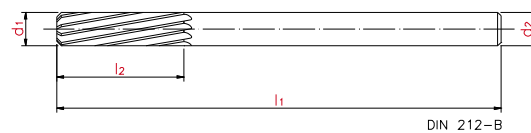
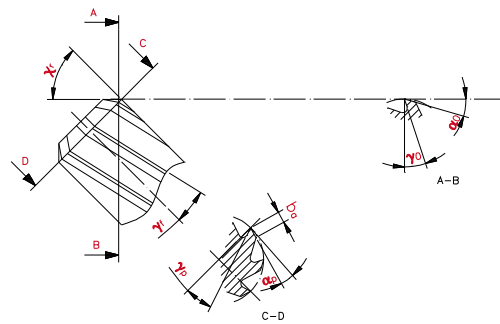
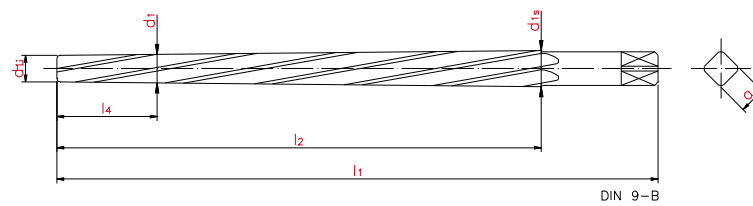

l1	Longitud total / Longueur totale / Total length
l2	Longitud de corte / Longueur de coupe / Length of cut
l4	Longitud hasta el diámetro nominal / Longueur jusqu'au diamètre nominal / Length to the nominal diameter
a	Cuadrado / Carré / Square
ba	Ancho de fase / Largeur de phase / Phase width
d1	Diámetro nominal / Diamètre nominal / Nominal diameter
d1i	Diámetro inferior / Diamètre inférieur / Inferior diameter
d1s	Diámetro superior / Diamètre supérieur / Superior diameter
d2	Diámetro de mango / Diamètre de queue / Shank diameter
di	Diámetro interior / Diamètre intérieur / Interior diameter
CM	Tamaño del cono morse / Taille du cône morse / Morse taper size
α0	Ángulo de destalonado / Angle de détalonnage / Relief angle
απ	Ángulo de destalonado del corte seco / Angle de détalonnage de la coupe sèche / Dry cut relief angle
γ0	Ángulo corte ortogonal / Angle coupe orthogonale / Orthogonal cut angle
γφ	Ángulo de corte lateral / Angle de coupe latérale / Lateral cut angle
γπ	Ángulo corte posterior / Angle coupe postérieure / Rear cut angle
χρ	Ángulo de posición / Angle de position / Angle of position

ESCARIADORES DE MANO ALÉSOIRS À MAIN / HAND REAMERS

4101 HSS DIN ≈ 206

Form.
B



Tol.
H7

ISO
236

P				M		K			N				S		H		
<800	<1.000	<1.200	<1.400	<950	<1.200	<500	<800	<1.400	Al	Cu	Mg/Zn	Plastic	Ni	Ti	50 HRC	55 HRC	60 HRC
•						•	•		•	•		•					

Vc (m/min). ● Optima / Optimun ○ Alternativo / Alternative



Ø mm	€	L mm	l mm	
1,50	76,18	41	20	1
2,00	21,43	50	25	1
2,25	23,56	54	27	1
2,50	21,43	58	29	1
2,75	23,56	62	31	1
3,00	21,43	62	31	1
3,25	61,11	66	33	1
3,50	21,43	71	35	1
3,75	61,11	71	35	1
4,00	21,43	76	38	1
4,25	61,11	76	38	1
4,50	22,40	81	41	1
4,75	61,11	81	41	1
5,00	22,40	87	44	1
5,25	61,11	87	44	1
5,50	22,40	93	47	1
5,75	61,11	93	47	1
6,00	22,40	93	47	1
6,25	61,11	100	50	1
6,50	22,40	100	50	1
6,75	61,11	107	54	1
7,00	22,40	107	54	1
7,25	61,82	107	54	1
7,50	23,63	107	54	1
7,75	61,82	115	58	1
8,00	23,63	115	58	1
8,25	61,82	115	58	1
8,50	24,83	115	58	1
8,75	61,82	124	62	1
9,00	24,83	124	62	1
9,25	61,82	124	62	1
9,50	25,87	124	62	1
9,75	118,48	133	66	1
10,00	25,87	133	66	1
10,25	118,48	133	66	1
10,50	32,79	133	66	1
10,75	118,48	142	71	1
11,00	32,79	142	71	1
11,25	118,48	142	71	1
11,50	118,48	142	71	1
11,75	126,35	142	71	1
12,00	35,24	152	76	1

Ø mm	€	L mm	l mm	
12,50	44,99	152	76	1
13,00	44,99	152	76	1
13,50	126,35	163	81	1
14,00	48,05	163	81	1
14,50	126,35	163	81	1
15,00	52,50	163	81	1
15,50	126,35	175	87	1
16,00	57,11	175	87	1
16,50	126,35	175	87	1
17,00	68,76	175	87	1
17,50	126,35	188	93	1
18,00	82,44	188	93	1
18,50	126,35	188	93	1
19,00	82,44	188	93	1
19,50	181,97	201	100	1
20,00	89,18	201	100	1
20,50	178,46	201	100	1
21,00	112,00	201	100	1
21,50	162,95	215	107	1
22,00	116,05	215	107	1
22,50	188,43	215	107	1
23,00	121,21	215	107	1
23,50	207,79	215	107	1
24,00	133,85	231	115	1
24,50	220,52	231	115	1
25,00	142,05	231	115	1
25,50	345,60	231	115	1
26,00	155,22	231	115	1
26,50	290,29	231	115	1
27,00	169,22	247	124	1
27,50	297,25	247	124	1
28,00	175,19	247	124	1
28,50	312,57	247	124	1
29,00	248,40	247	124	1
29,50	347,03	247	124	1
30,00	222,96	247	124	1
32,00	258,32	265	133	1
34,00	270,90	284	142	1
36,00	305,54	284	142	1
38,00	354,25	305	152	1
40,00	354,25	305	152	1

P Aceros
Aciers
Steels

M Aceros Inox
Aciers Inox
Stainless Steels

K Fundicion
Fonte
Cast Iron

N Metales no ferrosos
Métal non Ferraux
Non Ferrous metals

S Titanio y Superalaciones
Titanium et Supeallages
Titanium and Superalloys

H Materiales Duros
Materiels Durs
Hard materials

4102

HSS DIN 9

Form.

B



ISO

3465

P				M		K			N				S		H		
<800	<1.000	<1.200	<1.400	<950	<1.200	<500	<800	<1.400	Al	Cu	Mg/Zn	Plastic	Ni	Ti	50 HRC	55 HRC	60 HRC
•						•	•		•	•		•					

Vc (m/min). ● Optima / Optimun ○ Alternativo / Alternative



Ø Nom.	d ₁ mm	d ₂ mm	d mm	∠ mm	€	L mm	l mm	📦	Ø Nom.	d ₁ mm	d ₂ mm	d mm	∠ mm	€	L mm	l mm	📦
*1,50	2,14	1,40	3,15	2,40	50,07	57	37	1	6,00	8,00	5,90	8,00	6,20	28,35	135	105	1
2,00	2,86	1,90	3,15	2,40	38,55	68	48	1	*6,50	8,50	6,40	8,00	6,20	39,38	135	105	1
2,50	3,36	2,40	3,15	2,40	38,55	68	48	1	7,00	9,00	6,90	8,00	6,20	32,71	135	105	1
3,00	4,06	2,90	4,00	3,00	38,55	80	58	1	8,00	10,80	7,90	10,00	8,00	44,02	180	145	1
*3,50	4,56	3,40	4,50	3,00	42,32	87	63	1	10,00	13,40	9,90	12,50	10,00	54,62	215	175	1
4,00	5,26	3,90	5,00	3,80	23,32	93	68	1	12,00	16,00	11,80	14,00	11,00	73,46	255	210	1
*4,50	5,76	4,40	6,00	3,80	30,27	93	68	1	14,00	18,30	13,80	16,00	12,00	103,04	270	225	1
5,00	6,36	4,90	6,30	4,90	23,98	100	73	1	16,00	20,40	15,80	18,00	14,50	114,16	280	230	1
*5,50	7,18	5,40	6,30	4,90	37,99	118	89	1	20,00	24,80	19,80	22,40	18,00	157,15	310	250	1

*(Hasta fin de existencias / Jusqu'à épuisement des stocks / While supplies last)

4119

HSS

Form.

B



C. 1:16

(NFBSP1)

P				M		K			N				S		H		
<800	<1.000	<1.200	<1.400	<950	<1.200	<500	<800	<1.400	Al	Cu	Mg/Zn	Plastic	Ni	Ti	50 HRC	55 HRC	60 HRC
•						•	•		•	•		•					

Vc (m/min). ● Optima / Optimun ○ Alternativo / Alternative

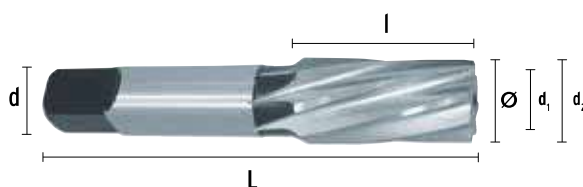

Ø Nom.	d ₁ mm	d ₂ mm	d mm	∠ mm	€	L mm	l mm	📦	Ø Nom.	d ₁ mm	d ₂ mm	d mm	∠ mm	€	L mm	l mm	📦
1/16	5,91	6,98	6	4,90	142,30	70	17	1	1/2	16,91	19,10	16	12,00	173,20	95	35	1
1/8	8,92	9,08	7	5,50	144,15	70	17	1	3/4	22,29	24,42	20	16,00	226,10	105	35	1
1/4	10,28	11,97	11	9,00	151,45	80	27	1	1"	27,97	30,66	25	20,00	287,95	130	43	1
3/8	13,70	15,39	12	9,00	157,65	85	27	1									

4118

HM-MD DIN 212

Form.
B-D



Tol.
H7

ISO
521

P				M		K			N				S		H		
<800	<1.000	<1.200	<1.400	<950	<1.200	<500	<800	<1.400	Al	Cu	Mg/Zn	Plastic	Ni	Ti	50 HRC	55 HRC	60 HRC
●	●	●	●	●	●	●	●	●	●	●	●	●	●	●	●	●	○
12-18	10-14	6-10	4-6	8-12	6-10	25-30	8-18	6-10	20-35	20-35	20-25	12-20	4-6	6-12	3-4	3-4	3-4

Vc (m/min). ● Optima / Optimun ○ Alternativo / Alternative

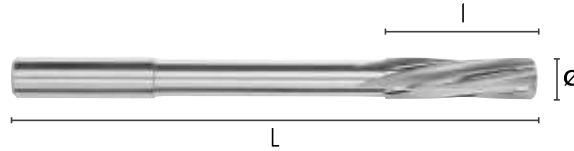

Ø mm	€	L mm	l mm	Icon	Ø mm	€	L mm	l mm	Icon
1,00	111,64	38	7	1	4,00	77,91	75	19	1
1,10	116,09	40	10	1	4,10	118,32	75	19	1
1,20	116,09	40	10	1	4,20	118,32	75	19	1
1,30	116,09	40	10	1	4,30	133,95	80	21	1
1,40	116,09	40	10	1	4,40	133,95	80	21	1
1,50	116,09	40	10	1	4,50	89,59	80	21	1
1,60	111,64	43	11	1	4,60	133,95	80	21	1
1,70	111,64	43	11	1	4,70	133,95	80	21	1
1,80	109,36	49	12	1	4,80	129,50	86	23	1
1,90	109,36	49	12	1	4,90	129,50	86	23	1
2,00	67,23	49	12	1	5,00	82,50	86	23	1
2,10	109,36	49	12	1	5,10	129,50	86	23	1
2,20	109,36	49	12	1	5,20	129,50	86	23	1
2,30	109,36	49	12	1	5,30	129,50	86	23	1
2,40	107,18	57	18	1	5,40	145,09	93	26	1
2,50	77,27	57	18	1	5,50	100,27	93	26	1
2,60	107,18	57	18	1	5,60	145,09	93	26	1
2,70	107,18	57	18	1	5,70	145,09	93	26	1
2,80	107,18	57	18	1	5,80	145,09	93	26	1
2,90	107,18	57	18	1	5,90	140,64	101	28	1
3,00	73,32	57	18	1	6,00	99,27	101	28	1
3,10	107,18	57	18	1	6,50	121,77	101	28	1
3,20	107,18	57	18	1	7,00	128,36	109	31	1
3,30	107,18	57	18	1	8,00	146,68	117	33	1
3,40	107,18	57	18	1	8,50	168,68	117	33	1
3,50	82,18	57	18	1	9,00	168,05	125	36	1
3,60	107,18	57	18	1	10,00	186,41	133	38	11
3,70	107,18	57	18	1	11,00	278,05	133	38	1
3,80	118,32	75	19	1	12,00	293,36	151	44	1
3,90	118,32	75	19	1					

4104

HSSCO DIN 212

Form. **B**
Ø ≤ 3,70

Form. **D**
Ø > 3,70



Tol. **H7**

ISO **521**

P				M		K			N				S		H		
<800	<1.000	<1.200	<1.400	<950	<1.200	<500	<800	<1.400	Al	Cu	Mg/Zn	Plastic	Ni	Ti	50 HRC	55 HRC	60 HRC
●	●	○		●	○	●	●		●	●	○	●	○	●			
8-14	6-8	4-6		6-8	4-6	12-16	6-12		14-25	12-25	12-16	8-14	1-3	2-8			

Vc (m/min). ● Optima / Optimun ○ Alternativo / Alternative

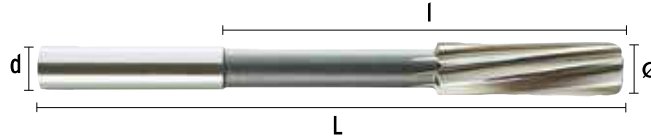

Ø mm	d mm	€	L mm	l mm		Ø mm	d mm	€	L mm	l mm	
1,00	1,00	38,63	34	7	1	6,20	6,30	30,23	101	28	1
1,20	1,20	38,63	34	7	1	6,30	6,30	30,23	101	28	1
1,40	1,40	34,63	40	8	1	6,40	6,30	30,23	101	28	1
1,50	1,50	34,63	40	8	1	6,50	6,30	23,31	101	28	1
1,60	1,60	34,63	43	9	1	6,60	6,30	30,23	101	28	1
1,80	1,80	34,63	46	10	1	6,70	6,30	30,23	101	28	1
1,90	1,90	34,63	46	10	1	6,80	7,10	30,23	109	31	1
2,00	2,00	34,63	49	11	1	6,90	7,10	30,23	109	31	1
2,10	2,10	34,63	49	11	1	7,00	7,10	23,31	109	31	1
2,20	2,20	34,63	53	12	1	7,10	7,10	30,23	109	31	1
2,30	2,30	34,63	53	12	1	7,20	7,10	30,23	109	31	1
2,40	2,40	30,58	57	14	1	7,30	7,10	30,23	109	31	1
2,50	2,50	30,58	57	14	1	7,40	7,10	30,23	109	31	1
2,60	2,60	30,58	57	14	1	7,50	7,10	25,28	109	31	1
2,70	2,70	28,29	61	15	1	7,60	8,00	33,40	117	33	1
2,80	2,80	28,29	61	15	1	7,70	8,00	33,40	117	33	1
2,90	2,90	28,29	61	15	1	7,80	8,00	33,40	117	33	1
3,00	3,00	21,25	61	15	1	7,90	8,00	33,40	117	33	1
3,10	3,10	27,52	65	16	1	8,00	8,00	25,77	117	33	1
3,20	3,20	27,52	65	16	1	8,10	8,00	38,40	117	33	1
3,30	3,30	27,52	65	16	1	8,20	8,00	38,40	117	33	1
3,40	3,40	27,52	70	18	1	8,30	8,00	38,40	117	33	1
3,50	3,50	21,25	70	18	1	8,40	8,00	38,40	117	33	1
3,60	3,60	27,52	70	18	1	8,50	8,00	28,21	117	33	1
3,70	3,70	27,52	70	18	1	8,60	9,00	38,40	125	36	1
3,80	4,00	27,52	75	19	1	8,70	9,00	38,40	125	36	1
3,90	4,00	27,52	75	19	1	8,80	9,00	38,40	125	19	1
4,00	4,00	21,25	75	19	1	8,90	9,00	38,40	125	36	1
4,10	4,00	27,52	75	19	1	9,00	9,00	31,02	125	36	1
4,20	4,00	27,52	75	19	1	9,10	9,00	38,40	125	36	1
4,30	4,50	27,52	80	21	1	9,20	9,00	38,40	125	36	1
4,40	4,40	27,52	80	21	1	9,30	9,00	38,40	125	36	1
4,50	4,50	21,25	80	21	1	9,40	9,00	38,40	125	36	1
4,60	4,50	27,52	80	21	1	9,50	9,00	31,51	125	36	1
4,70	4,50	27,52	80	21	1	9,60	10,00	42,22	133	38	1
4,80	5,00	27,52	86	23	1	9,70	10,00	42,22	133	38	1
4,90	5,00	27,52	86	23	1	9,80	10,00	42,22	133	38	1
5,00	5,00	21,25	86	23	1	9,90	10,00	42,22	133	38	1
5,10	5,00	27,52	86	23	1	10,00	10,00	31,51	133	38	1
5,20	5,00	27,52	86	23	1	11,00	10,00	37,23	142	41	1
5,30	5,00	27,52	86	23	1	12,00	10,00	36,39	151	44	1
5,40	5,60	27,52	93	26	1	13,00	10,00	62,56	151	44	1
5,50	5,60	21,25	93	26	1	14,00	12,50	59,82	160	47	1
5,60	5,60	27,52	93	26	1	15,00	12,50	65,32	162	50	1
5,70	5,60	27,52	93	26	1	16,00	12,50	69,92	170	52	1
5,80	5,60	27,52	93	26	1	17,00	14,00	80,63	175	54	1
5,90	5,60	27,52	93	26	1	18,00	14,00	84,07	182	56	1
6,00	5,60	23,31	93	26	1	19,00	16,00	89,32	189	58	1
6,10	6,30	30,23	101	28	1	20,00	16,00	89,95	195	60	1

4104/1

HSSCO DIN 212

Form. **B**
Ø ≤ 3,70

Form. **D**
Ø > 3,70



ISO **521**

P				M		K			N				S		H		
<800	<1.000	<1.200	<1.400	<950	<1.200	<500	<800	<1.400	Al	Cu	Mg/Zn	Plastic	Ni	Ti	50 HRC	55 HRC	60 HRC
●	●	○		●	○	●	●		●	●	○	●	○	●			
8-14	6-8	4-6		6-8	4-6	12-16	6-12		14-25	12-25	12-16	8-14	1-3	2-8			

Vc (m/min). ● Optima / Optimun ○ Alternativo / Alternative

Ø mm	€	L mm	l mm	
0,95 - 1,31	40,73	34	5-7	1
1,32 - 1,54	36,52	40	8	1
1,55 - 1,70	36,52	43	9	1
1,71 - 1,90	36,52	46	10	1
1,91 - 2,12	36,52	49	11	1
2,13 - 2,36	36,52	53	12	1
2,37 - 2,66	32,25	57	14	1
2,67 - 3,05	29,86	61	15	1
3,06 - 3,35	29,86	65	16	1
3,36 - 3,75	33,53	70	18	1
3,76 - 4,25	33,53	75	19	1
4,26 - 4,75	32,68	80	21	1
4,76 - 5,30	32,68	86	23	1
5,31 - 5,95	33,08	93	26	1
5,96 - 6,00	33,89	93	26	1
6,01 - 6,70	33,89	101	28	1
6,71 - 7,29	37,34	109	31	1

Ø mm	€	L mm	l mm	
7,30 - 7,55	41,97	109	32	1
7,56 - 8,50	41,97	117	33	1
8,51 - 9,25	47,40	125	36	1
9,26 - 9,50	54,10	125	36	1
9,51 - 10,64	52,04	133	38	1
10,65 - 11,25	61,10	142	41	1
11,26 - 11,80	62,74	142	41	1
11,81 - 12,02	62,74	151	44	1
12,03 - 13,02	86,27	151	44	1
13,03 - 13,20	86,27	151	44	1
13,21 - 14,00	104,87	160	47	1
14,01 - 14,02	104,87	162	50	1
14,03 - 15,00	127,90	162	50	1
15,01 - 15,02	127,90	170	52	1
15,03 - 16,00	136,92	170	52	1
16,01 - 16,02	136,92	175	54	1

4105

HSSCO DIN 212

Form. **E**



ToL. **H7**

ISO **521**

P				M		K			N				S		H		
<800	<1.000	<1.200	<1.400	<950	<1.200	<500	<800	<1.400	Al	Cu	Mg/Zn	Plastic	Ni	Ti	50 HRC	55 HRC	60 HRC
●									●	●		●					
10-16									14-25	14-20		10-16					

Vc (m/min). ● Optima / Optimun ○ Alternativo / Alternative



Ø mm	d mm	€	L mm	l mm	
3,00	3,00	29,15	61	15	1
3,50	3,50	29,15	70	18	1
4,00	4,00	29,15	75	19	1
4,50	4,50	29,69	80	21	1
5,00	5,00	29,69	86	23	1
5,50	5,60	29,69	93	26	1
6,00	5,60	29,69	93	26	1
6,50	6,30	34,51	101	28	1
7,00	7,10	30,20	109	31	1
7,50	7,10	35,16	109	31	1
8,00	8,00	30,77	117	33	1

Ø mm	d mm	€	L mm	l mm	
8,50	8,00	39,08	117	33	1
9,00	9,00	34,20	125	36	1
9,50	9,00	39,08	125	36	1
10,00	10,00	34,20	133	38	1
11,00	10,00	52,68	142	41	1
12,00	10,00	50,72	151	44	1
13,00	10,00	59,63	151	44	1
14,00	12,50	64,17	160	47	1
15,00	12,50	86,24	162	50	1
16,00	12,50	107,30	170	52	1

4103

HSSCO DIN 2179

Form.
E



ISO
3466

P				M		K			N				S		H		
<800	<1.000	<1.200	<1.400	<950	<1.200	<500	<800	<1.400	Al	Cu	Mg/Zn	Plastic	Ni	Ti	50 HRC	55 HRC	60 HRC
● 6-12	○ 4-6			○ 4-6		● 10-14	● 6-8		● 8-22	● 10-22		● 14-22		○ 4-6			

Vc (m/min). ● Optima / Optimun ○ Alternativo / Alternative

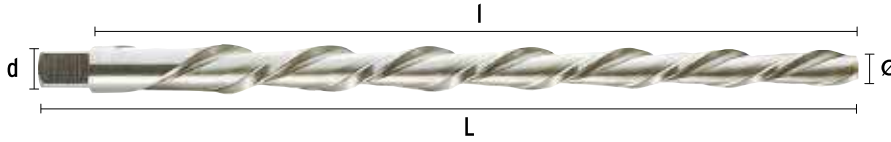

Ø Nom.	D mm	d mm	€	L mm	l mm	Icon	Ø Nom.	D mm	d mm	€	L mm	l mm	Icon
3,00	4,06	2,90	27,56	100	58	1	6,00	8,00	5,90	49,57	160	105	1
4,00	5,26	3,90	44,80	112	68	1	8,00	10,80	7,90	79,59	207	145	1
5,00	6,36	4,90	42,70	122	73	1	10,00	13,40	9,90	157,93	245	175	1

4106

HSSCO DIN 208

Form.
B



Tol.
H7

ISO
521

P				M		K			N				S		H		
<800	<1.000	<1.200	<1.400	<950	<1.200	<500	<800	<1.400	Al	Cu	Mg/Zn	Plastic	Ni	Ti	50 HRC	55 HRC	60 HRC
● 8-14	● 6-8	○ 4-6		● 6-8	○ 4-6	● 12-16	● 6-12		● 14-25	● 12-25	● 12-16	● 8-14	○ 1-3	○ 2-8			

Vc (m/min). ● Optima / Optimun ○ Alternativo / Alternative



Icon	Ø mm	€	L mm	l mm	Icon	Icon	Ø mm	€	L mm	l mm	Icon
1	4,00	53,54	129	19	1	2	16,00	63,77	210	52	1
1	5,00	38,80	133	23	1	2	16,50	84,36	214	54	1
1	5,50	47,68	138	26	1	2	17,00	71,28	214	54	1
1	6,00	39,36	138	26	1	2	18,00	75,75	219	56	1
1	6,50	48,62	144	28	1	2	19,00	79,29	223	58	1
1	7,00	40,04	150	31	1	2	20,00	82,32	228	60	1
1	7,50	33,02	150	31	1	2	21,00	102,13	232	62	1
1	8,00	40,99	156	33	1	2	22,00	108,65	237	64	1
1	8,50	52,73	156	33	1	2	23,00	113,49	241	66	1
1	9,00	43,84	162	36	1	3	24,00	137,55	268	68	1
1	9,50	53,23	162	36	1	3	25,00	140,29	268	68	1
1	10,00	41,59	168	38	1	3	26,00	146,92	273	70	1
1	10,50	53,94	168	38	1	3	27,00	169,05	277	71	1
1	11,00	42,14	175	41	1	3	28,00	169,05	277	71	1
1	11,50	56,84	175	41	1	3	29,00	184,18	281	73	1
1	12,00	42,14	182	44	1	3	30,00	184,18	281	73	1
1	12,50	66,64	182	44	1	3	31,00	235,25	285	75	1
1	13,00	55,29	182	44	1	4	32,00	220,44	317	77	1
1	13,50	68,62	189	47	1	4	34,00	231,57	321	78	1
1	14,00	56,85	189	47	1	4	35,00	266,73	321	78	1
2	14,50	72,25	204	50	1	4	36,00	342,71	325	79	1
2	15,00	58,57	204	50	1	4	38,00	364,91	329	81	1
2	15,50	75,92	210	52	1	4	40,00	372,32	329	81	1

4107

HSSCO DIN 208

Form.

C



Tol.

H7

ISO

521

P				M		K			N				S		H		
<800	<1.000	<1.200	<1.400	<950	<1.200	<500	<800	<1.400	Al	Cu	Mg/Zn	Plastic	Ni	Ti	50 HRC	55 HRC	60 HRC
●				●		●	●	●	●	●	●	●					
10-16									14-25	14-20		10-16					

Vc (m/min). ● Optima / Optimun ○ Alternativo / Alternative



▽	▽	Ø mm	€	L mm	l mm	📦
1	1	5,00	65,70	133	23	1
1	1	6,00	65,70	138	26	1
1	1	7,00	65,70	150	31	1
1	1	8,00	65,70	156	33	1
1	1	9,00	63,29	162	36	1
1	1	10,00	63,29	168	38	1
1	1	11,00	66,08	175	41	1
1	1	12,00	66,08	182	44	1
1	1	13,00	98,30	182	44	1
1	1	14,00	101,36	189	47	1
2	2	15,00	110,97	204	50	1
2	2	16,00	116,35	210	52	1

▽	▽	Ø mm	€	L mm	l mm	📦
2	2	17,00	125,92	214	54	1
2	2	18,00	133,77	219	56	1
2	2	19,00	141,91	223	58	1
2	2	20,00	149,19	228	60	1
2	2	21,00	161,23	232	62	1
2	2	22,00	172,07	237	64	1
2	2	23,00	184,53	241	66	1
3	3	24,00	194,64	268	68	1
3	3	25,00	206,62	268	68	1
3	3	26,00	218,05	273	70	1
3	3	28,00	241,06	277	71	1
3	3	29,00	253,66	281	73	1

4108

HSS DIN 311



ISO

2238



P				M		K			N				S		H		
<800	<1.000	<1.200	<1.400	<950	<1.200	<500	<800	<1.400	Al	Cu	Mg/Zn	Plastic	Ni	Ti	50 HRC	55 HRC	60 HRC
●	○			○		●	○	●	●	●	●	●		○			
6-12	4-6			4-6		10-14	6-8		8-22	10-22		14-22		4-6			

Vc (m/min). ● Optima / Optimun ○ Alternativo / Alternative



▽	▽	Ø mm	€	L mm	l mm	📦
1	1	10,00	62,22	171	95	1
1	1	11,00	63,92	176	100	1
2	2	12,00	66,20	199	105	1
2	2	13,00	72,09	199	105	1
2	2	14,00	79,41	209	115	1
2	2	15,00	83,42	219	125	1
2	2	16,00	87,58	229	135	1
3	3	17,00	113,12	251	135	1
3	3	18,00	117,04	261	145	1
3	3	19,00	120,38	261	145	1
3	3	20,00	122,56	271	155	1
3	3	21,00	134,87	271	155	1
3	3	22,00	140,75	281	165	1
3	3	23,00	150,92	281	165	1

▽	▽	Ø mm	€	L mm	l mm	📦
3	3	24,00	161,46	296	180	1
3	3	25,00	172,11	296	180	1
3	3	26,00	187,94	296	180	1
3	3	27,00	201,75	311	195	1
3	3	28,00	220,40	311	195	1
3	3	29,00	236,54	311	195	1
3	3	30,00	236,99	311	195	1
3	3	31,00	240,95	326	210	1
4	4	32,00	262,29	354	210	1
4	4	33,00	350,10	364	220	1
4	4	34,00	370,01	364	220	1
4	4	35,00	389,03	364	220	1
4	4	36,00	452,10	364	220	1
4	4	37,00	472,00	364	220	1

4115 HSSCO 5%

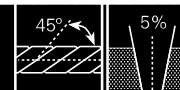

P				M		K			N				S		H		
<800	<1.000	<1.200	<1.400	<950	<1.200	<500	<800	<1.400	Al	Cu	Mg/Zn	Plastic	Ni	Ti	50 HRC	55 HRC	60 HRC
● 6-12	○ 4-6			○ 4-6		● 10-14	● 6-8		● 8-22	● 10-22		● 14-22		○ 4-6			

Vc (m/min). ● Optima / Optimun ○ Alternativo / Alternative



Ø Nom.	€	D mm	d mm	L mm	l mm	
3,00	103,66	3	6	110	60	1
4,00	139,59	4	8	130	80	1
5,00	171,36	5	10	155	100	1

Ø Nom.	€	D mm	d mm	L mm	l mm	
6,00	211,09	6	12	180	120	1
7,00	271,77	7	14	200	140	1

4116 HSSCO 8%

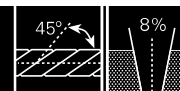

P				M		K			N				S		H		
<800	<1.000	<1.200	<1.400	<950	<1.200	<500	<800	<1.400	Al	Cu	Mg/Zn	Plastic	Ni	Ti	50 HRC	55 HRC	60 HRC
● 6-12	○ 4-6			○ 4-6		● 10-14	● 6-8		● 8-22	● 10-22		● 14-22		○ 4-6			

Vc (m/min). ● Optima / Optimun ○ Alternativo / Alternative



Ø Nom.	€	D mm	d mm	L mm	l mm	
3,00	85,91	3	8	110	62	1
4,00	105,63	4	10	130	75	1

Ø Nom.	€	D mm	d mm	L mm	l mm	
5,00	139,22	5	12	150	90	1
6,00	159,60	6	14	160	100	1

4117 HSSCO 10%

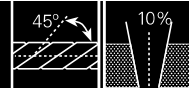

P				M		K			N				S		H		
<800	<1.000	<1.200	<1.400	<950	<1.200	<500	<800	<1.400	Al	Cu	Mg/Zn	Plastic	Ni	Ti	50 HRC	55 HRC	60 HRC
●	○			○		●	●		●	●		●		○			
6-12	4-6			4-6		10-14	6-8		8-22	10-22		14-22		4-6			

Vc (m/min). ● Optima / Optimun ○ Alternativo / Alternative

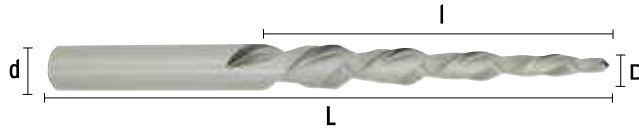

Ø Nom.	€	D mm	d mm	L mm	l mm	
2,00	81,48	2	6	90	40	1
3,00	101,20	3	8	100	50	1
4,00	127,08	4	10	115	60	1

Ø Nom.	€	D mm	d mm	L mm	l mm	
5,00	128,17	5	12	130	70	1
6,00	224,65	6	14	140	80	1

4109 HSS DIN 219

Form. **B**



Tol. **H7**

ISO **2402**

P				M		K			N				S		H		
<800	<1.000	<1.200	<1.400	<950	<1.200	<500	<800	<1.400	Al	Cu	Mg/Zn	Plastic	Ni	Ti	50 HRC	55 HRC	60 HRC
●	○			●		●	●		●	○		●		○			
8-14	6-8			6-8		12-16	6-12		14-25	16-25		12-16	8-14	1-3	2-8		

Vc (m/min). ● Optima / Optimun ○ Alternativo / Alternative



Ø mm	Ø int.	€	L mm	l mm	
32,00	16,00	101,33	50	36	1
34,00	16,00	112,35	50	36	1
36,00	19,00	128,63	56	40	1
38,00	19,00	137,03	56	40	1
42,00	19,00	155,93	56	40	1
45,00	22,00	183,23	63	45	1
47,00	22,00	194,25	63	45	1
48,00	22,00	205,80	63	45	1
52,00	27,00	249,90	71	50	1

Ø mm	Ø int.	€	L mm	l mm	
55,00	27,00	277,20	71	50	1
58,00	27,00	292,43	71	50	1
62,00	32,00	356,48	80	56	1
65,00	32,00	392,70	80	56	1
70,00	32,00	430,50	80	56	1
72,00	40,00	495,60	90	63	1
75,00	40,00	539,70	90	63	1
80,00	40,00	587,48	90	63	1

4114 Mandrino / Mandrin / Mandrel



∆	∅ mm	D mm	€	L mm	📦
3	31,00 - 35,00	16	226,10	260	1
4	36,00 - 42,00	19	261,44	298	1
4	43,00 - 50,00	22	332,08	310	1

∆	∅ mm	D mm	€	L mm	📦
5	51,00 - 60,00	27	491,06	325	1
5	61,00 - 71,00	32	589,98	376	1
5	72,00 - 85,00	40	748,99	396	1

4110 Extensible / Extendible

Form. **A** REFORZ. REINFORC. REINFORC.

P				M		K			N				S		H		
<800	<1.000	<1.200	<1.400	<950	<1.200	<500	<800	<1.400	Al	Cu	Mg/Zn	Plastic	Ni	Ti	50 HRC	55 HRC	60 HRC
•						•	•		•	•		•					

Vc (m/min). ● Optima / Optimun ○ Alternativo / Alternative

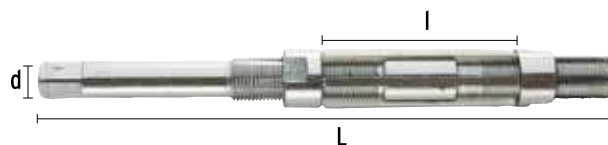

∅ mm	d mm	€	L mm	l mm	📦	€ JUCHILLAS J.LAMES/SET OF BLADES
8,00-9,00	4,50	118,14	100	35	1	74,53
9,00-10,00	5,50	118,14	120	39	1	74,53
10,00-11,00	5,90	118,14	125	40	1	74,53
11,00-12,00	6,50	118,14	130	43	1	74,53
12,00-13,50	7,50	118,14	135	46	1	74,53
13,50-15,50	8,00	118,14	140	51	1	74,53
15,50-18,00	9,50	125,71	165	61	1	78,04
18,00-21,00	12,00	130,13	185	66	1	82,26

∅ mm	d mm	€	L mm	l mm	📦	€ JUCHILLAS J.LAMES/SET OF BLADES
21,00-24,00	13,50	151,40	195	70	1	94,69
24,00-27,50	15,00	164,85	215	83	1	99,70
27,50-31,50	18,50	180,27	240	88	1	109,64
31,50-37,00	21,00	234,99	265	91	1	134,88
37,00-45,00	25,00	350,37	310	110	1	208,76
45,00-55,00	32,00	504,09	380	128	1	321,05
55,00-67,00	42,00	916,60	440	150	1	486,48
67,00-80,00	45,00	1.389,87	490	170	1	739,20

4111

Extensible guía / Extensible guide / Extendible guide

Form.
A

P				M		K			N				S		H		
<800	<1.000	<1.200	<1.400	<950	<1.200	<500	<800	<1.400	Al	Cu	Mg/Zn	Plastic	Ni	Ti	50 HRC	55 HRC	60 HRC
•						•	•		•	•		•					

Vc (m/min). ● Optima / Optimun ○ Alternativo / Alternative



∅ mm	d mm	€	L mm	l mm	J.CUCHILLAS J.LAMES/SET OF BLADES	∅ mm	d mm	€	L mm	l mm	J.CUCHILLAS J.LAMES/SET OF BLADES		
8,00-9,00	4,50	151,83	175	35	1	74,53	21,00-24,00	13,50	168,60	320	70	1	94,69
9,00-10,00	5,50	151,83	185	35	1	74,53	24,00-27,50	15,00	179,25	350	83	1	99,70
10,00-11,00	5,90	151,83	195	40	1	74,53	27,50-31,50	18,50	229,45	385	88	1	109,64
11,00-12,00	6,50	151,83	200	41	1	74,53	31,50-37,00	21,00	342,42	424	91	1	134,88
12,00-13,50	7,50	151,83	220	44	1	74,53	37,00-45,00	25,00	498,57	490	110	1	208,76
13,50-15,50	8,00	151,83	243	53	1	74,53	45,00-55,00	32,00	714,58	600	128	1	321,05
15,50-18,00	9,50	160,94	274	61	1	78,04	55,00-67,00	42,00	1.140,10	740	150	1	486,48
18,00-21,00	12,00	160,94	300	66	1	82,26	67,00-80,00	45,00	1.568,49	830	170	1	739,20