



Innovating Plastic Values



 **新緯機械股份有限公司**
SHINE WELL MACHINERY CO., LTD.

台南市安南區開安路51號
No.51, Kai An Rd., Tainan City, 709, Taiwan.
TEL:+886-6-3563470
FAX:+886-6-3560082
info@shinwell.com.tw
www.shinwell.com.tw



Agent

CX-Ca-14-09-V03-CE

 **Series**



**SERVO ENERGY SAVING
INJECTION MOLDING MACHINE**

◆ 伺服節能射出成型機 ◆



新緯機械股份有限公司
SHINE WELL MACHINERY CO., LTD.

At a glance 概述

New design of 5-point high speed toggle mechanism
Effectively reduces 30% dry cycle time, provides larger size of tie bar clearance and platen layout, and more moulds can be loaded.

新研發五點式高速曲手機構

縮短30%空循環時間，柱內空間及模板尺寸加大

Wide selection of injection modules for single clamping unit

Injection unit is upgraded as per specific molding term needed. Charging on fly as optional feature to save total cycle time.

模組化射出單元

依特殊成型條件選用適合射出單元
選配開模中儲料雙迴路，縮短循環時間



Austrian KEBA I series control

Intelligent HMI supporting by high durability hardware. Rotatable control panel with graphic display and interface of auxiliary is more user-friendly.

KEBA I型控制器

智慧化人機介面搭配高規格硬體支援
旋轉式控制面板搭配圖像化及週邊設備界面，使用者操控更便利

Independent circuit to control, power and servo system, for easy maintenance and avoid interference issue.

控制、動力及伺服系統獨立線路，方便維修及避免干擾問題產生

Fortified machine frame design makes fast motions more stable.

強化機架設計使機械動作運行更穩定

Starting on conventional horizontal 4-point toggle of AT model, to vertical 5-point toggle of B model, the brand new CX series horizontal 5-point high speed toggle design aims to bring best machine performance and production efficiency to end users.

由傳統水平四點式曲手AT機種，到垂直五點式曲手B系列，新一代CX系列垂直五點式高速曲手設計，將帶給使用者更好的機械性能及更高的生產效率。

Modularized hydraulic unit

Hydraulic components set as per pump flow capacity or special circuit design.

模組化液壓單元

依動力源大小或特殊需求獨立安裝相關油壓組件



Rx & ASE series servo energy saving unit

Saving energy waste up to 70% and upgrading precision of hydraulics.

Rx及ASE系列伺服節能系統

節能效果較傳統機省能源70%以上，大幅降低生產成本及能源浪費，並提升油壓控制精準度

Thousands-based of single lubrication cycle reduces grease consumption and extend commissioning life of toggle components.

日系電動黃油泵

專用油脂耐高壓耐磨耗，潤滑模次增加油耗量少，可延長曲手軸/銅套壽命

- ★ logic valves hydraulic design to various units 全邏輯閥油路系統
- ★ linear guideway movement for injection unit 射出單元採線性滑軌移動
- ★ twin sets of injection cylinder 雙組射出油壓缸
- ★ easy access to maintenance 保養簡單、維修容易
- ★ and more.....

Machine feature concept 機械特徵

Clamping concept 鎖模單元

Optimized design of 5-point high speed twin toggle mechanism. Upgrading toggle magnification and the ratio of clamping cylinder stroke into opening stroke, so dry cycle is more than 30% reduced. Platen size and tie bar clearance are extended for loading various sizes of injection moulds.

五點式高速雙曲手組設計，放大曲手倍率及增加油壓缸/開模行程比率，大幅減少機台乾跑時間；模板尺寸及四柱內距加大，模具可選用尺寸增加。

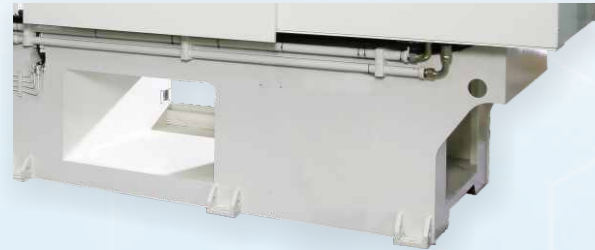

Three ways of drop chute facilitates integration of auxiliary equipment like conveyor for increase production efficiency.

成品落下區域採三向式設計，方便機台搭配輸送帶使用，提高生產效率



Movable platen is box-shaped design with T-slot and tapped mounting layout; platen thickness and rigidity are upgraded to minimize deformation. Self-lubricated compounded plate is installed at bottom to move less friction to steel tape during mould motions. The option of linear guide way supporting mould open/close is available.

活動模板採箱型結構及T型槽加鑽孔模面設計，模板厚度及剛性增加，變形量小。底部支撐滑腳加裝自潤滑板減少開關模阻力。亦可選用線性滑軌輔助開關模動作。

Centralized grease lubricator made by Japan LUBE brand. Special design of grease tube with characteristics of high pressure capability and wear-resistant can take perfect lubrication effect. Averagely 3000 or more moulds of lubrication cycle makes less grease consumption and the alarm of lubrication fail is to prevent short supply in case of pipe damage.

集中式潤滑系統，配合使用日本LUBE專用耐高壓耐磨耗黃油條潤滑。單次三千模以上潤滑週期使黃油耗量少，並設有潤滑失敗警報，避免因管線破裂導致曲手軸/銅套缺乏潤滑而磨耗。



Hydraulic and programmed low pressure protection with precision less than 0,1mm can make sure no damage of mould landing area on condition of part drop failed.

油壓式及電控低壓鎖模保護，準確度達0.1mm，當成型品頂出時未落下，模具關模至低壓點會立即停止以確保模具表面不損壞。

Parallel ejector during opening performs by general hydraulic design or electro-drive control, for shortening total cycle time. (Optional)

可選用油壓式開模中頂出複合動作，減少生產週期時間。(選配功能)

Injection concept 射出單元



The movement of double injection cylinders is supported by linear guide ways to achieve perfect positional precision and smooth move at injection performance.

射出座及馬達座採用線性滑軌移動，增加精準度且降低射出作動及射座移動之阻力。

Quick-removed adapter of carriage cylinder makes simple separation of injection unit. By swiveling 60 degree onwards to operation side, screw or barrel is easily taken apart and changed by hanger or crane. Dual carriage cylinders support sufficient nozzle contact force and ensure no melt leakage from mould gate.

雙射座油壓缸接頭採快拆式設計，底座向操作側旋轉約60度即可輕鬆更換螺桿或料管組，減少維修及停機時間。安裝雙組射座油壓缸提供足夠噴嘴接觸力，確保射出時塑料不洩漏。



Barrier type or mixing screw design with multi-notch screw tip are available (optional), at least 18 times of effective L/D ratio assures good plasticizing capacity, avoids the issue of short-filling under short cycle and stabilizes shot weight of finished part. Multiple barrel temperature zones with PID control practically carry out stability of barrel heating and quality of melt.

特殊螺桿設計，螺桿有效長徑比達18倍以上，提升可塑化能力，在快速生產情況下避免短射問題，同時保持成型品重量穩定度。料管溫度採多段PID控制，具體實現溫度穩定度。

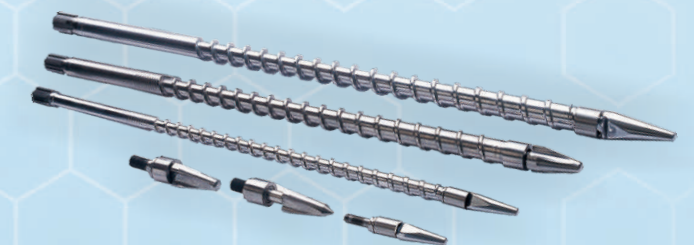

| | | | | | | | | | | | | | | |
|----------------------|--------------------------------------|----------|----------|----------|----------|----------|----------|----------|----------|----------|----------|------------|-------------|-------------|
| 特殊尺寸 Special Size | On request | | | | | | | | | | | | | |
| 16810 | | | | | | | | | | | | | 130 140 | 130 140 150 |
| 12672 | | | | | | | | | | | | 110 120 | 110 120 130 | 110 120 130 |
| 8472 | | | | | | | | | | | 95 100 | 95 100 110 | 95 100 110 | |
| 5437 | | | | | | | | | 85 90 | 85 90 95 | 85 90 95 | | | |
| 4316 | | | | | | | | 80 85 | 80 85 90 | 80 85 90 | | | | |
| 3079 | | | | | | | 70 75 | 70 75 80 | 70 75 80 | | | | | |
| 2101 | | | | | | 60 65 | 60 65 70 | 60 65 70 | | | | | | |
| 1727 | | | | | 55 60 | 55 60 65 | 55 60 65 | | | | | | | |
| 1400 | | | | 50 55 | 50 55 60 | 50 55 60 | | | | | | | | |
| 1078 | | | 45 50 | 45 50 55 | 45 50 55 | | | | | | | | | |
| 764 | | 40 45 | 40 45 50 | 40 45 50 | | | | | | | | | | |
| 517 | 36 40 | 36 40 45 | 36 40 45 | | | | | | | | | | | |
| 387 | 32 36 | 32 36 40 | 32 36 40 | | | | | | | | | | | |
| 167 | 25 28 32 | 25 28 32 | | | | | | | | | | | | |
| | 60 | 100 | 130 | 160 | 200 | 250 | 300 | 350 | 450 | 550 | 700 | 950 | 1250 | 1600 |
| | 600 | 1000 | 1300 | 1600 | 2000 | 2500 | 3000 | 3500 | 4500 | 5500 | 7000 | 9500 | 12500 | 16000 |
| | Ton | | | | | | | | | | | | | |
| | kN | | | | | | | | | | | | | |
| | 鎖模單元 CLAMPING UNIT Clamping Force | | | | | | | | | | | | | |

Modularized injection unit is installed as per injection pressure, speed, shot weight, etc. specifically for various molding terms. Three sizes of screw selected and may revise on request.

射出單元模組化。根據成型品或塑料特性所需之射出壓力、速度或重量等條件，安裝適合的射出單元，滿足各式成型需求。

ACC injection with servo closed-loop circuit for upgrading injection speed and positional accuracy (optional).

可加裝蓄壓器及伺服閥作閉迴路射出，提升射速及成型位置切換精準度。

Charge on fly by means of hydraulic or electro-driven for improving cycle time and productivity (optional).

選配開模中儲料雙迴路(油壓式/電動式)系統，縮短生產循環時間、提升產能。

Feed throat temperature control is to against irregular material supply thanks to overheating. (Optional)

料斗下料口溫度控制，避免塑料進入料管時的溫度已過高而造成儲料動作不正常。(選配功能)

Hydraulic concept 油壓單元

Integrated hydraulic circuit design for less hydraulic efficiency loss. Injection and clamping manifolds are standard feature of logic valve for performing without delay and responding at shortest time.

New servo system has no issues of heat generation from pressure/speed proportional valve, neither of oil drain by variable pump, oil temperature maintains regularly. The capacity of oil tank is about 50% requiring in comparison of conventional fixed pump machine, but on condition of non-stop production, oil quality stays good as temperature is stable and low. Commissioning high efficiency heat exchanger also upgrades cooling capacity and cooling water is therefore less consumed.

Movable oil tank for complete container clean and oil change. Modularized oil tank capacity is flexible set up basing on real pump flow and specific drive unit, or synchronous hydraulic functions.

Outside-mounted filter is given at source of suction circuit to percolate contaminations producing from oil tank, easy filter cleaning and decrease possibility of pump failure. Optional 3R filter for return circuit ensures double purification of action oil and extends oil lifecycle.

As per environmental conditions of high/low room temperature in different countries or regions, auxiliary tools such as oil pre-heat device and cooling valve can be installed for maintaining oil temperature and minimizing energy waste.

整合式油路系統、射出及鎖模油路板搭配標準邏輯閥切換控制，機械動作接續流暢無延遲。

新一代伺服系統無傳統射出機總壓閥洩壓或迴油造成油溫上升的問題，油箱容量為傳統機一半節省注油量；機台即使長時間運轉油溫不會過高，液壓油不易變質。使用高效率熱交換器增加冷卻能力，可減少冷卻水使用量。

移動式油箱設計，在更換液壓油時油箱易清理；油箱容量模組化，根據系統流量大小或複合油壓動作，安裝適當容量之油箱及組件。

油箱安裝箱外型濾油網，清洗容易並可確保泵浦吸油時無汙染源，降低泵浦損壞率；迴油亦可選用濾油網，增加油質潔淨度及耐用度。

依據不同國家或地區環境條件，機台可選擇加裝油溫預熱裝置或油溫控制電磁閥，將能源損耗量減至最低。



Servo system 伺服系統

SVP Servo Pump Energy Saving Unit

The SVP system is developed by German Rexroth that consists of synchronous rotary speed controlled servo motor with driver of control section and internal gear pump. System software is inclusive of a set of closed loop pressure and flow controller. The switch over from flow to pressure control and backwards is done automatically by the software. The controller has been optimized to avoid pressure overshoot during switch over from flow to pressure control.

There are two command values of pressure and flow from a PLC required. The medium of transmission is according to the model ordered (i.e. analogue, bus system). Meanwhile, on the same way actual values of both signals are sent back to the PLC. Pressure command is compared with the actual value of pressure measured by the transducer and revised tolerance within 50ms. The control error is processed in a special tailored PID controller and output signal of pressure controller is rotary speed. For the machines of higher flow capacity or with simultaneous functions, the Master-Slave system is applied by one master servo unit combining one or multiple slave servo units that can supply sufficient flow for single machine.

Another cost-effective utilization is by ASE energy saving system. It consists of control driver of ABB brand, synchronous servo motor by Taiwanese brand and German made internal gear pump. Pressure is controlled by fast proportional valve on a basis of closed-loop process, while flow is supplied by rotary speed of servo motor timing displacement of gear pump. Motor rpm is tuned by the detection of encoder to have correct speed so as to have exact system flow. ASE servo system is beneficial for economic users.

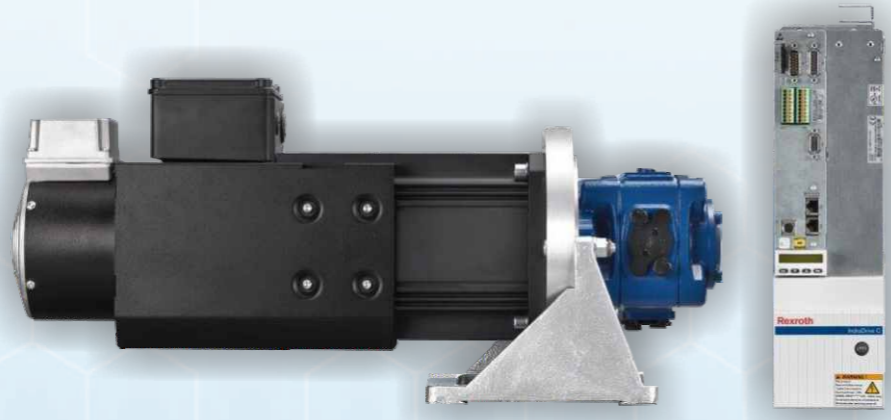

SVP伺服系統為德國Rexroth品牌，包含同步式伺服馬達、伺服驅動器及高壓內齒輪泵浦。系統壓力及流量採全閉迴路控制；壓力設定命令值和感測器演算出實際值之間的誤差由驅動器於50毫秒內作動態修正，反饋輸出訊號並立即調整轉速，以消除誤差值。而流量由伺服馬達轉速乘以泵浦吐出量作速度控制，無傳統機依設定速度大小需作洩油動作而耗費多餘能源。流量較大或有複合式動作之機台，可應用主-從伺服模式(Master-Slave)以提供機台足夠流量。MBE機種另提供ASE型節能伺服系統，選用ABB品牌驅動器，搭配德製高壓內齒輪泵浦及台製伺服馬達，節能效果媲美SVP系統，提供經濟型客戶另一項選擇。

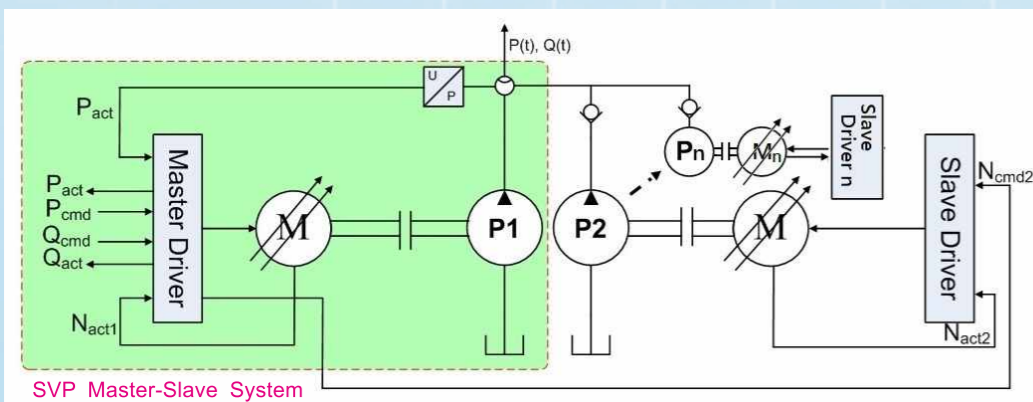

FEATURES 特性

* Effective Energy Saving:

By various setups of molding terms, machine consumes energy 40% less than the machine with variable displacement pump or inverter, and averagely 60% less comparing to the machine with fixed displacement pump.

* Higher Precision :

Closed-loop pressure and flow controller perfectly transmits commands and real values of different functions. The controller receives command from PLC, inspects real value of working devices (pressure sensor and encoder), then giving feedback signal to PLC for micro tuning. The tolerance of linearity and hysteresis for pressure and flow is less than 1% that substantially improves molding precision.

* Better Dynamics :

The response time of pressure and flow between servo drive and motor is less than 50 ms, instantly switching over of pressure/flow to rise or decrease tolerance. As specific pressure or speed is required, servo motor runs proper rotary speed to reduce energy waste.

* Outstanding Efficiency :

No issues of heat generation of hydraulic oil causing from relief valves of fixed displacement pump and drain of variable displacement pump, so a smaller capacity of heat exchanger and less volume of cooling water are required. The capacity of oil tank is cut to half that reduces oil storage and cost of refilling. A standard hydraulic design of logic circuit is to shorten response moment of hydraulics and achieve pressure/speed control precisely.

* Stable Operation :

Perfect integration of mechanical, hydraulic and control sections upgrades machine performance and molding reliability.

* 節能效果佳 :

在不同成型條件下，伺服節能機台較搭配變量泵或變頻器之機台節能達40%以上，與傳統固定泵機台比較更可節能60%以上。

* 高精準度 :

機械動作採閉環迴路控制，壓力及速度實際值經由壓力傳感器或編碼器傳送至PLC做誤差偵測，並回授馬達做調整，以消除誤差值。整體系統直線性及再現性誤差在1%以下，改善成型精密度。

* 高應答性 :

壓力及速度在驅動器與伺服馬達間之應答時間小於50毫秒，立即調整誤差值；驅動器根據所設定之壓力或速度，回饋信號於伺服馬達提供適當的轉速，減少能源浪費。

* 油壓系統最佳化 :

無傳統機搭配固定泵作動時需做洩壓，及變量泵作動時需迴油而產生油溫上升的問題，熱交換器可選用較小規格且冷卻水使用量有效減少。油溫不會因長時間生產大幅上升，油箱散熱面積及容量可減少一半以上，油品不易變質，延長換油頻率及降低換油成本。全機種採用邏輯式油路設計，動作反應時間短且精確作動所需壓力及速度。

* 機台性能穩定 :

機械結構、油路設計及控制電路完美整合，提升機械性能及成型的穩定度。

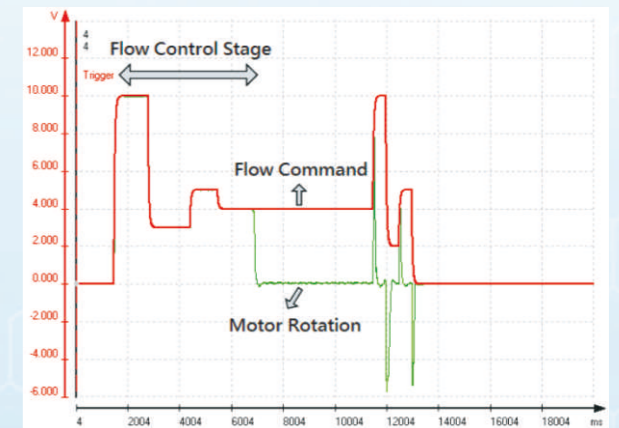
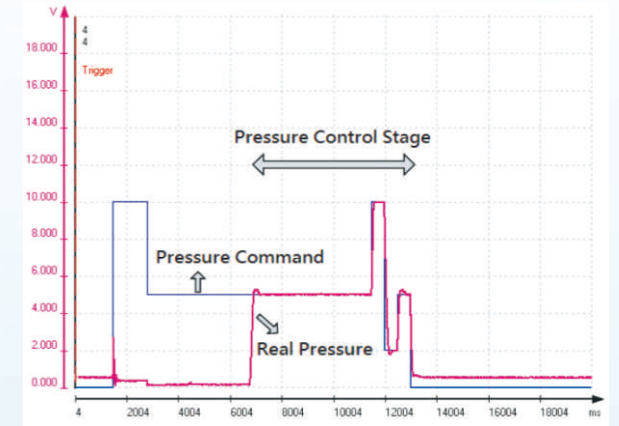

Hardware/Interfaces 硬體/介面

- By means of maximum integration density, the high-performance, single-board computer furnishes all defined I/Os required for the operation of IMM.
- Machine and molding data are stored to compact flash card for easy and swift data transferring from machine to machine and reduce halt time.
- Several kinds of interface can be configured, including: graphics, CAN bus, serial port, terminal temperature sensor, USB Port and Ethernet.
- Optimized 2A digital outputs with minimum switching times for hydraulic valves
- 採用高性能單板控制器並高度整合了所有射出機所需標準I/O模組，減少空間使用。
- 機台及模具參數儲存於CF卡內，可輕易且迅速將資料移轉至其他機台上，減少停機故障時間。
- 多種標準硬體介面可供連接，包含：圖像式介面、CAN通訊、序列埠、溫度模組、USB埠及Ethernet等。
- 高度優化2A數位輸出可直接驅動油壓閥，縮短反應時間。



Functions 功能

- Euromap 12 or 67 robot interface available, or by defined I/O of robot connection configured in PLC.
- Injection process diagram displays for easy tuning of molding parameters.
- Integrating mould hot runner system under control mask for simplifying at same interface (optional).
- Service masks: configuring time setup of service items for reminding operator a regular machine maintenance work.
- Modular application software quickly delivers tailor-made solutions for various molding requirements and special machine features.
- Regulated injection process with automatic tuning.
- SPC (statistic process control) package
- 歐規12或67機械手連結或控制器定義機械手連接IO點介面。
- 射出過程曲線監視使成形條件調整更容易。
- 可整合模具熱澆道系統於控制頁面下便於監控及調整(選配功能)。
- 提供多種機台定期保養項目之時間設定(根據週期或運轉時間)，提醒使用者定時執行維護工作。
- 多種模組化軟體應用提供安裝以因應各種特殊成型條件或機械動作，做即時客製化修改，達到最佳機台工作效率。
- 射出過程閉迴路自動調校。
- 成型統計資料頁面。

Operation 操控

- Standard 10.4" display with 256,000 colors and resolution of 800x600 pixels for easy operation and monitoring.
- Operation by membrane keypad with well layout of pre-defined motion buttons and tactile feedback for comfortable control by user.
- Ethernet connection EasyNet program offers users a simple, user-friendly control station for operating by identical surface, managing machine and quality data centrally and monitoring real status all the time to commissioning machines and therefore increases working efficiency (optional).
- The operator or manager can key-in password to enter different operation tiers and observe the masks or machine status accordingly.
- The parameters of each machine motion are set by specific mask; monitoring mask displays by graphic bars and real values.
- 標準10.4吋TFT-LCD、256,000色全彩高解析度螢幕，讓使用者更容易操作及監控。
- 使用薄膜式鍵盤並將各機械動作按鍵完整配置，讓使用者操控機械更友善且輕易上手。
- EasyNet遠端監視功能提供使用者一個淺顯易懂的控制平台；透過與成型機相同操控介面的平台，使用者可輕易整合所有機台的機械及成型資料，紀錄參數並監控機台狀態，大幅提升整廠工作效率。
- 操作者或管理者可依不同密碼設定進入獨立監控層級，以檢視機台頁面或狀態。
- 機械各動作頁面獨立設定，監視頁面動作狀態圖像及數據顯示，清楚且容易操作。

